

CITIZEN

# Cincom

## M16

Sliding Headstock Type CNC Automatic Lathe



# The M16: A high-end model covering $\phi 16$ mm.

**The M16: A high-end model covering  $\phi 16$  mm. The B axis function of rotary tools on the gang tool post and the back tool post Y axis function give the advantage with complex shapes and secondary machining.**

The M16 type VIII features a B axis for rotary tools on the gang tool post. It can machine angled holes and complex shapes. The swivel angle of the B axis is  $135^\circ$  and it can be used in both front and back machining. The back tool post is equipped with a Y axis (types VII and VIII) and up to 9 tools can be carried in 3 rows. But we have not just upped the number of controlled axes and the number of mountable tools. In addition to upping the rapid feed rate to 32 m/min and running high-speed calculation with the latest NC unit,

the maximum rotational speeds of the front/back spindles and the rotary tools on the turret tool post have also been increased. By machining with the optimum conditions for small-diameter workpieces and small-diameter drills/end mills, high productivity can be achieved. The M16 brings advanced functions and raises the level of the basic functions. It permits greater versatility in workpiece shapes, and has the edge when machining the increasingly complex parts for the IT and medical fields.



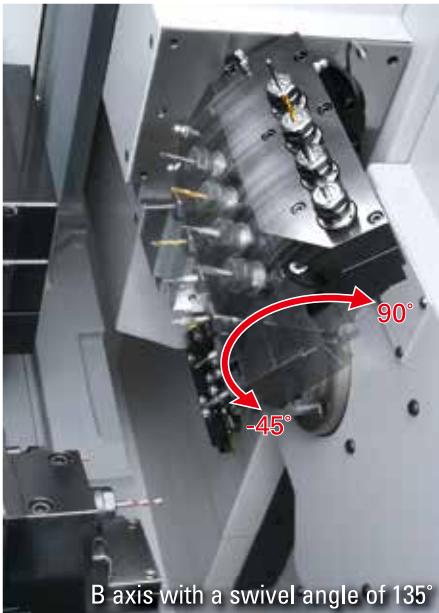

### Rotary tools on the gang tool post equipped with B axis \*Type VIII

On the M16 type VIII, the rotary tools on the gang tool post feature a B axis as standard, and four tools each can be mounted for back and front machining. The swivel angle has a range of 135°, from 90° to -45°, and the machine is capable of contouring using 4-axis control, with the B axis used even in back machining.



### Y axis incorporated in the turret tool post

Because the 10-station turret tool post incorporates a Y axis, a wide variety of secondary machining is possible. The tool post can be indexed without going back to the return position, shortening tool change times. Each tool station is driven and can carry multi-tool holder.

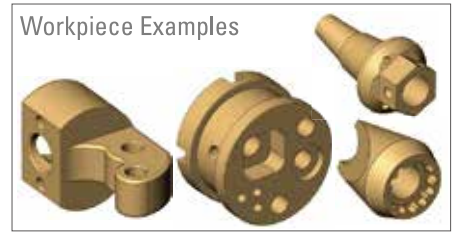

### Y axis incorporated in the back tool post \*Types VII and VIII

The back tool post can accommodate nine tools in 3 rows of 3 tools. The specifications of the outer diameter milling spindle (MSC507), 3-drilling spindle (MSE607) and 3-sleeve holder (MDF107) are common to those used on the gang tool post and they can be used both on the gang tool post and the back tool post.

## M16 VIII Tooling example

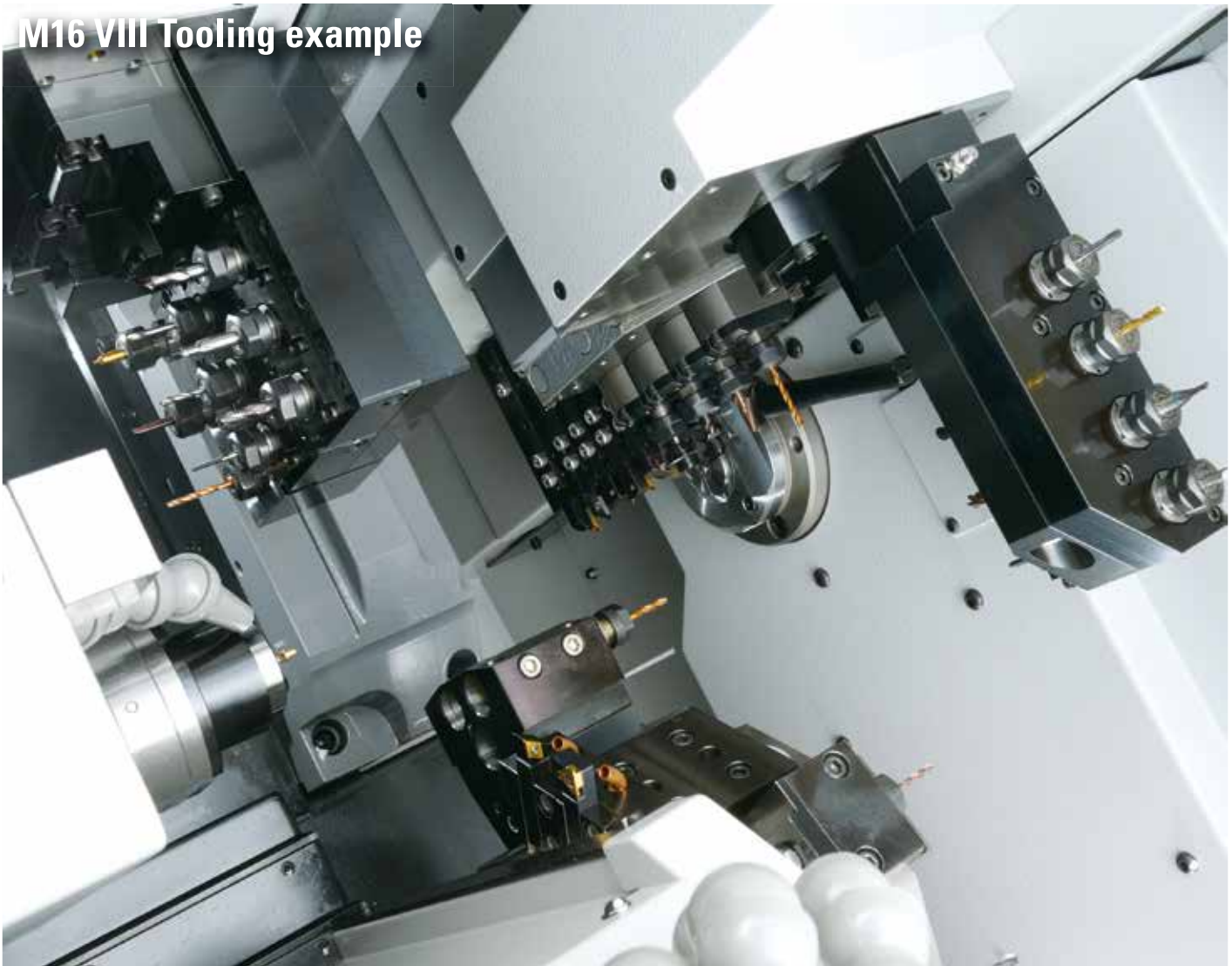

# Faster. Achieving a higher level of stable operation

## High speed and excellent maintainability linked to productivity improvements

### Rapid feed rate of 32 m/min, and 20% reduction in idle time

The rapid feed rate of the major feed axes has been substantially increased to 32 m/min. The adoption of the latest NC unit with a high-speed CPU on board, in combination with Citizen's original control technology "Cincom Control", cuts idle time by 30%.

### High-speed spindle and tool spindle

High-speed rotation has been achieved for the front/back spindles with their maximum speed of 12,000 min<sup>-1</sup>, and for the gang tool spindle, turret tool spindle and back tool post tool spindle\* types VII and VIII with their maximum speed of 8,000 min<sup>-1</sup>. This means that the optimum machining conditions can be used when machining small-diameter bar material and when using small diameter drills/end mills.

### Air Seals

Air seals are used as a standard feature in the front spindle, guide bushing and rear spindle, and this restricts the entry of coolant and chips and guarantees stable operation for extended periods.

### Central lubrication device

A central lubrication device is installed as standard. The automatic supply of lubricating oil to all ball screws eliminates the need for manual greasing and improves maintainability.

### Oil supply to rotary tools on the gang tool post

The gang tool post rotary tool drive device is equipped with an automatic lubrication function as standard, limiting wear of the gears over the long term and assuring high reliability.

### Cincom Control

"Cincom Control" is Citizen's unique control system specially developed to enable smooth motion at high speeds. It slashes idle time without adversely affecting cutting, achieving a remarkable reduction of cycle time.

### Idling Stop

When the spindles and feed axes are stopped, for example during editing, the servo turns OFF and the amount of power in the standby status is reduced. Note that the cumulative reduction in the amount of power since installation can be checked on the Eco screen.





# Operability fully considered too, with 3 types selectable to match the application

Type V for excellent cost performance, Type VII featuring a Y3 axis,  
and Type VIII featuring a gang tool B axis

## M16 Type VIII

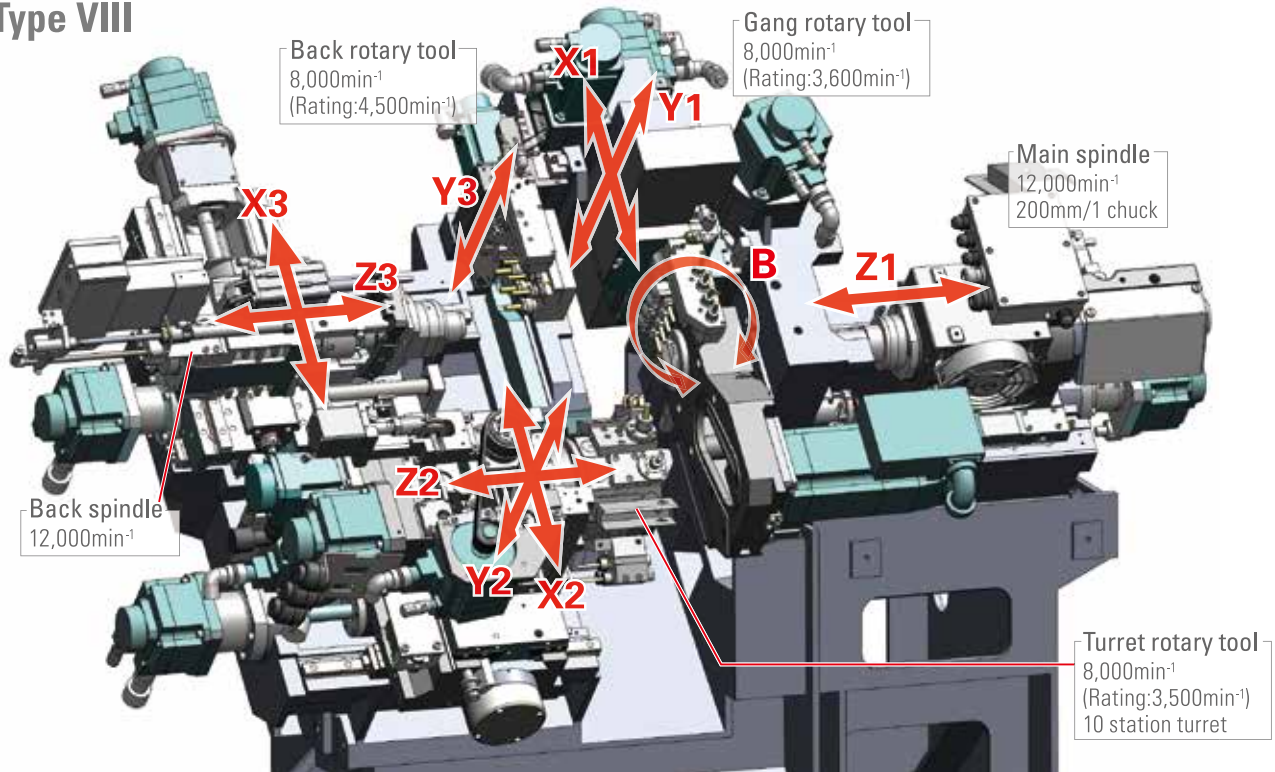

### Back tool post of the Type V M16

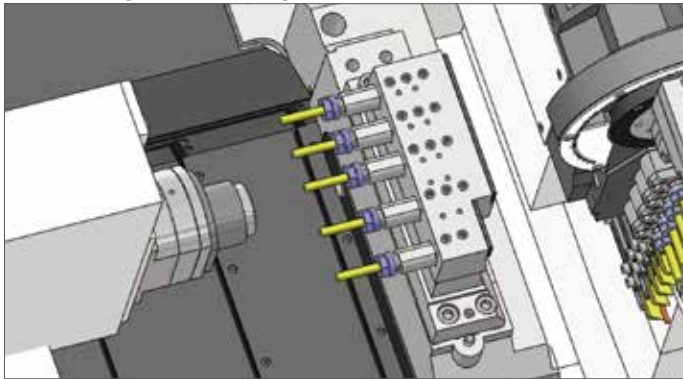

### M16 configuration according to type

	Type V	Type VII	Type VIII
Y2 axis (turret Y axis)	○	○	○
Y3 axis (back tool post Y axis)	—	○	○
B axis (rotary tools on the gang tool post)	—	—	○



### Swing-out operation panel

The operation panel with high visibility color screen that pivots about two points, enabling it to be conveniently positioned for tasks such as editing and tool setting.



### Product collection

Machined products are consigned to this receiver box through the turret-mounted basket. Products up to 125 mm in length can be collected. Optional accessories include workpiece conveyor and workpiece unloader.



### Oil cooler fitted as standard for rotary tools

For rotary tools on the gang tool post and rotary tools on the back tool post, an oil cooler is installed as standard.

# Intuitive screen display is easy to view and read

## Screen designed from the operator's perspective, and comfortable to use



### Equipped with high-speed NC

The machine is equipped with the latest NC model to drastically reduce the startup and screen switching time compared to conventional machines with advanced functions. This feature provides a stress-free operation environment.



### On-machine program check function

Using the manual pulse handle, an NC program can be run forward and backward so that the program can be edited by stopping the operation at a desired point and then resuming according to the edited program.

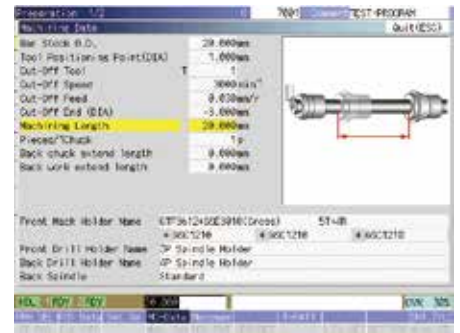

### Display of easily understood illustrations

The corresponding illustration is displayed on the screen so that the operator can easily recognize the meaning of the associated data.

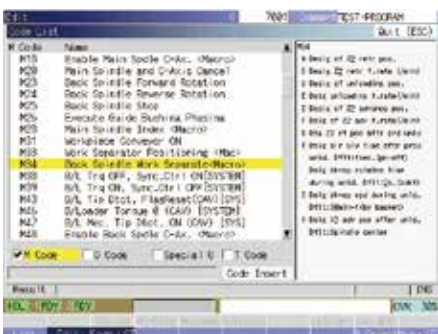

### Display of code list

The function displays the list of G and M codes including explanations of the arguments to support programming.

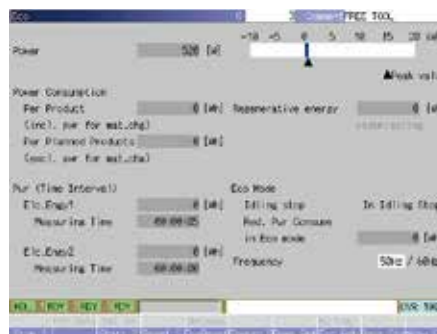

### Eco screen

The current power consumption is shown on the screen, along with the maximum power consumption value, the power consumption record, the cumulative power consumption, and the power regeneration (generation) status. Data can be output, too.

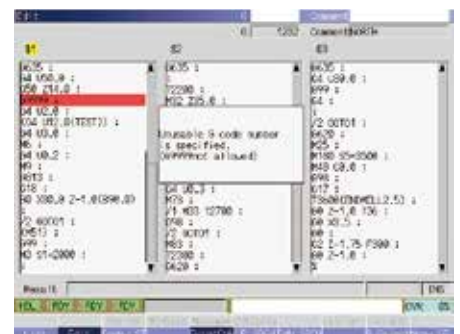

### Grammar check function

The customer can check whether there are any syntax errors in the program before running it. And if an alarm occurs, the relevant block is highlighted.

# Fast, safe and accurate collection of workpieces

## Product Unloader

By installing a product unloader, the collection time with the turret can be reduced, helping to shorten cycle times. The unloader can collect products with lengths from 125 to 400 mm, and can also be used in combination with the long workpiece unit that draws the products out from the rear of the back spindle with a work hand.



## Chip conveyor

Two models of chip conveyor are available: the U90J, a tank-integrated model that can be used with the long workpiece device, and the U95J, which allows easy chip collection with a chip track.

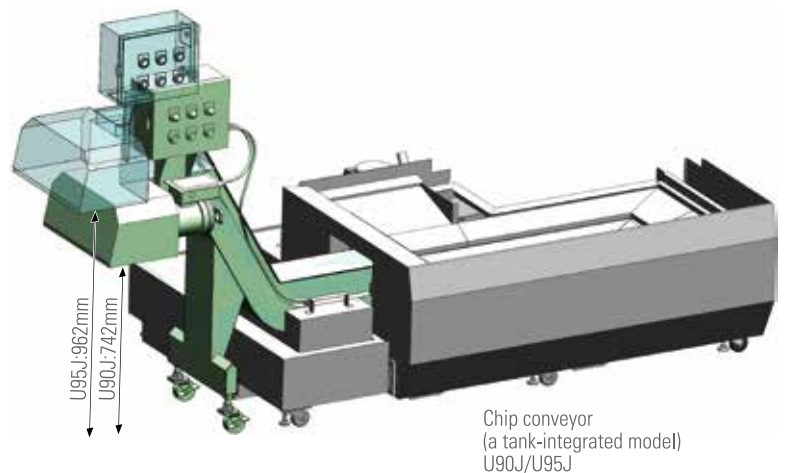

# Machine Layout

## M16 Standard Machine Layout

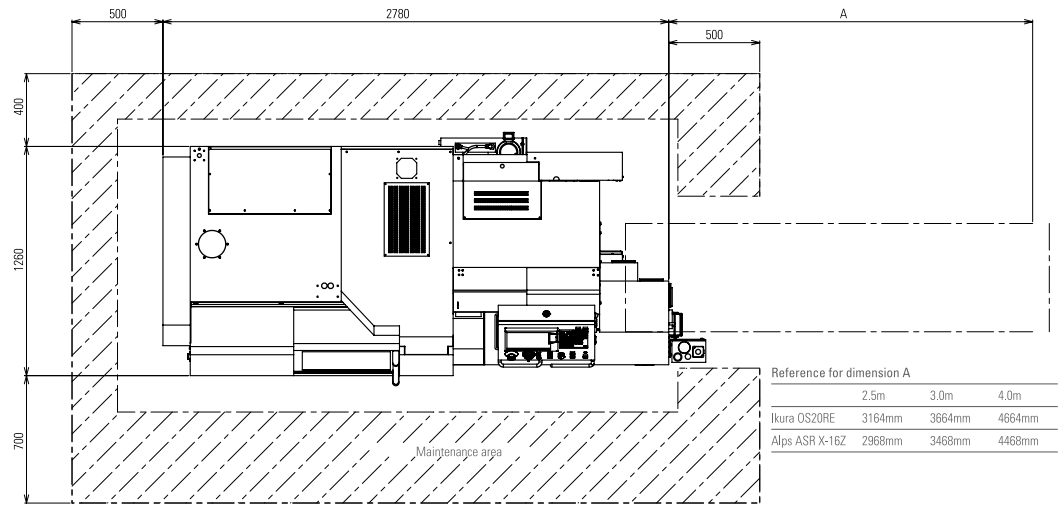

Reference for dimension A

	2.5m	3.0m	4.0m
Ikura OS20RE	3164mm	3664mm	4664mm
Alps ASR X-16Z	2968mm	3468mm	4468mm

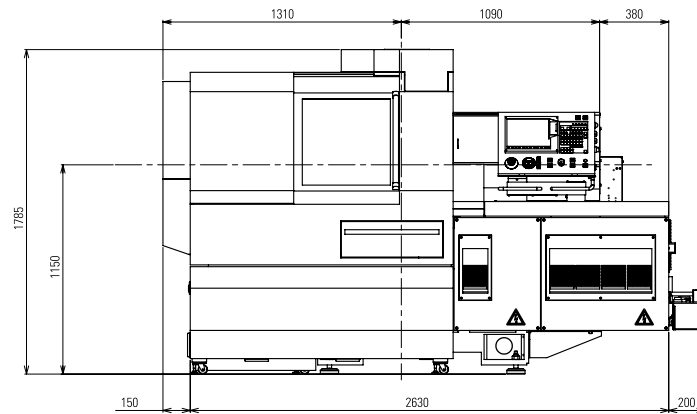
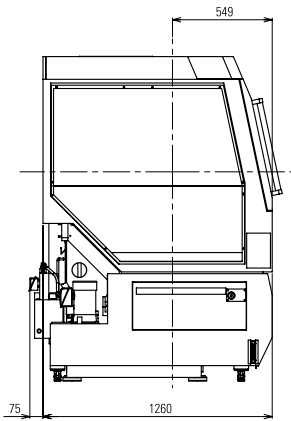

## M16 Option-installed Machine Layout

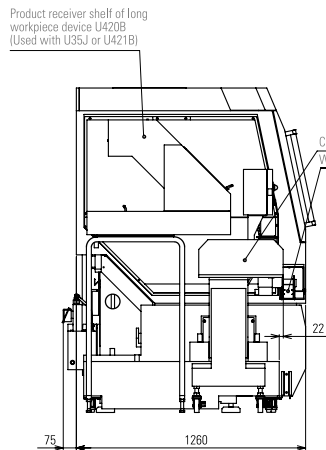
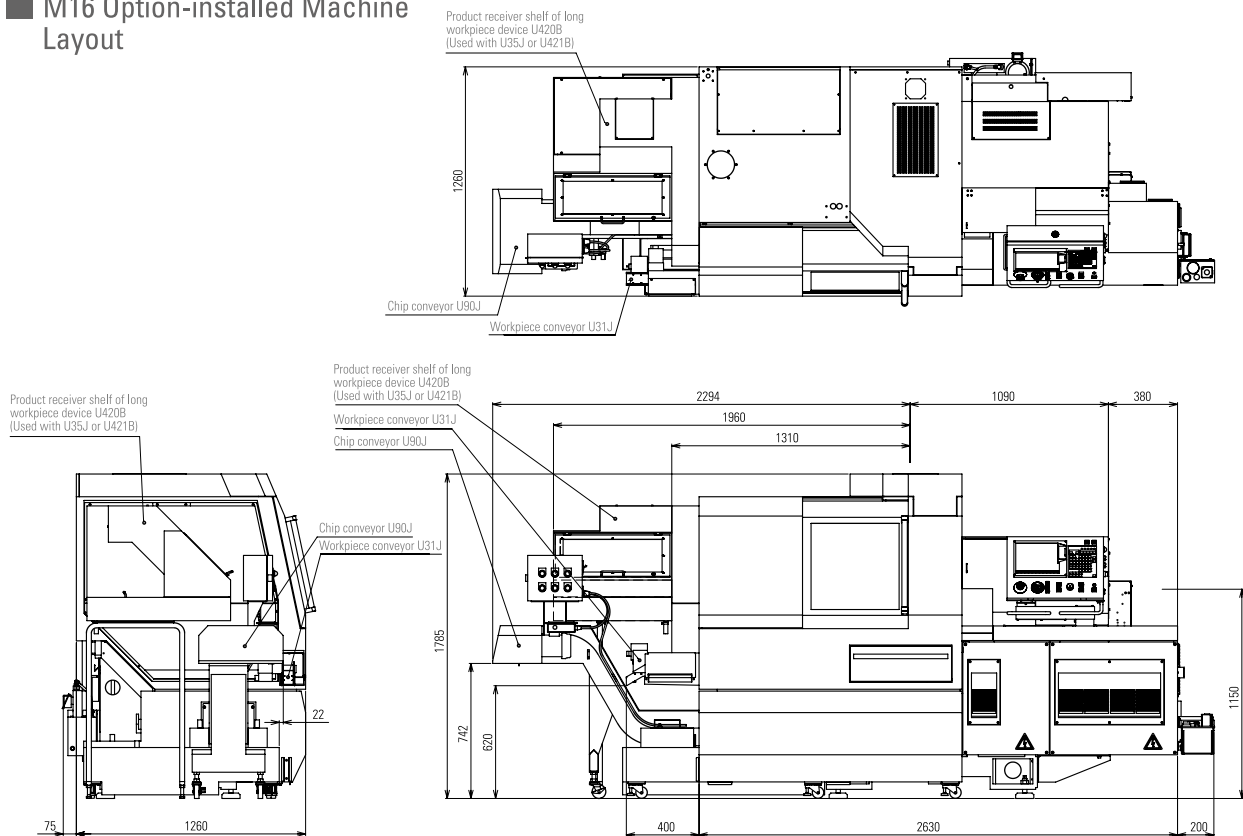

Status with M416, U420B, U31J, U90J fitted



# Machine Specification

Item	M16		
	Type V (M16-4M5)	Type VII (M16-4M7)	Type VIII (M16-4M8)
Max. machining diameter (D)	∅16mm		
Max. machining length (L)	200mm/1 chucking		
Max. front drilling diameter	∅10mm		
Max. front tapping diameter (tap, die)	M8 (tap), M6 (die)		
Spindle through-hole diameter	∅20mm		
Main spindle speed	Max.12,000min <sup>-1</sup>		
Max. chuck diameter of the back spindle	∅16mm		
Max. protrusion length	125mm		
Max. protrusion length of the back spindle workpiece	30mm		
Max. drilling diameter for the back spindle	∅8mm		
Max. tapping diameter for the back spindle	M6		
Back spindle speed	Max.12,000min <sup>-1</sup>		
Gang rotary tool			
Max. drilling diameter	∅5mm		
Max. tapping diameter	M5		
Spindle speed	Max.8,000min <sup>-1</sup> (Rating 3,600min <sup>-1</sup> )		
Turret rotary tool			
Max. drilling diameter	∅5mm		
Max. tapping diameter	M5		
Spindle speed	Max.8,000min <sup>-1</sup> (Rating 3,500min <sup>-1</sup> )		
Back tool post rotary tool			
Max. drilling diameter	—	∅5mm	
Max. tapping diameter	—	M5	
Spindle speed	—	Max.8,000min <sup>-1</sup> (Rating 4,500min <sup>-1</sup> )	
Number of tools to be mounted	32+α	36+α	
Gang turning tool	5		
Gang rotary tool	5~12(including back 4 tools)		
Turret	10+α		
Back tool post	5	9	
Tool size			
Tool (turning tool)	□10mm		
Sleeve	∅19.05mm		
Main spindle collet chuck	FC261-M		
Guide bushing	FC261-M-K		
Back spindle collet chuck	WFG660-M		
Rapid feed rate			
All axes (except X2, Y2, Y3 & B axes)	32m/min		
X2 axis	16m/min		
Y2 axis	8m/min		
Y3 axis	—	32m/min	
Motors			
Spindle drive	2.2/3.7kW		
Gang tool post rotary tool drive	0.69kW		
Turret rotary tool drive	0.69kW		
Back spindle drive	0.75/1.5kW		
Back tool post rotary tool drive	—	0.75kW	
Coolant oil	0.4kW		
Center height	1,150mm		
Rated power consumption	7.9kVA		
Full-load current	28A		
Main breaker capacity	40A		
Air pressure and air flow rate for pneumatic devices	0.5MPa, 84NL/min (normal) / 220NL/min (blow)		
Weight	2,900kg	2,950kg	

Standard accessories	
Main spindle chucking unit	Air-driven knock-out device for back machining
Rotary guide bushing unit	Workpiece separator
Back spindle chucking unit	Machine relocation detector
Gang rotary tool driving unit	Door lock
Coolant unit (with level detector)	Lighting
Lubricating oil supply unit (with level detector)	
Special accessories	
Cut-off tool breakage detector	Motor-driven knock-out device for back machining
Knock-out jig for through-hole workpiece	Workpiece conveyor
Long workpiece unit	Chip conveyor
Product unloader	Signal lamp
Coolant flow rate detector	3-color signal tower
Medium-pressure coolant unit	
Standard NC functions	
NC unit dedicated to the L12 (M730LPC-4VS)	Automatic power-off function
10.4 inch color liquid crystal display (LCD)	On-machine program check function
Program storage capacity : 40m (approx.16KB)	Nose radius compensation
Tool offset pairs : 40	Chamfering, corner R
Product counter indication (up to 8 digits)	Format check function
Operating time display function	Alarm block display function
Spindle speed change detector	Eco display
Constant surface speed control function	Machine operation information display
Spindle C-axis function	
Special NC functions	
Variable lead thread cutting	Program storage capacity : 1200m (approx.480KB)
Arc threading function	Tool offset pairs : 80
Geometric function	Tool life management I
Spindle synchronized function	Tool life management II
Milling interpolation	External memory program driving
Back spindle 1° indexing function	Network I/O function
Back spindle C-axis function	Submicron commands
Back spindle chasing function	User macros
Canned cycle drilling	Helical interpolation function
Rigid tapping function	Inclined helical interpolation function
High speed Rigid tapping function	Hob function
Rigid tapping phase adjustment function	Polygon function
Differential speed rotary tool function	Inch command
Optional block skip (9 sets)	Sub inch command
Back machining program skip function	3D chamfering function

# Environmental Information

Basic Information	Energy usage	Power supply voltage	AC200V
		Electrical power requirement	7.9kVA
		Required pneumatic pressure	0.5MPa
Environmental Performance Information	Power consumption	Standby power *1	0.448kW
		Power consumption with model workpiece *2	0.013kWh/cycle
		Power consumption value above converted to a CO <sub>2</sub> value *3	6.15g/cycle
	Air consumption	Required air flow rate	84NL/min (max. 220 NL/min., during air blow)
	Lubricant consumption	At power ON	2.5cc/30min
Approach to Environmental Issues	Noise level	Value measured based on JIS	80dB
	Environmental load reduction	RoHS Directive / REACH regulations	Compliant
	Recycling	Indication of the material names of plastic parts	Covered in the instruction manual *4
Environmental management		We are ISO14001 accredited. We pursue "Green Procurement", whereby we make our purchases while prioritizing goods and services that show consideration for the environment.	

\*1 : This is the standby power in the idle stop mode (a function that turns servomotor excitation off when it is not necessary, for example during program editing).

\*2 : This is the power consumption in program operation (when not cutting) for one of our standard test pieces, shown for the purpose of comparing the environmental performance with that of existing models.

\*3 : This is the value converted in accordance with the CHUBU Electric Power CO<sub>2</sub> emissions coefficient for 2009 as published by the Ministry of the Environment.

\*4 : If polyvinyl chloride (PVC) and fluorine resin are not processed correctly they can generate harmful gases. When recycling these materials, commission a contractor that is capable of processing them appropriately.

## CITIZEN MACHINERY CO., LTD.

# CITIZEN

<b>JAPAN</b>	CITIZEN MACHINERY CO., LTD. 4107-6 Miyota, Miyota-machi, Kitasaku-gun, Nagano-ken, 389-0206, JAPAN	TEL.81-267-32-5901	FAX.81-267-32-5908
<b>SOUTH ASIA / KOREA</b>	CITIZEN MACHINERY CO., LTD. 4107-6 Miyota, Miyota-machi, Kitasaku-gun, Nagano-ken, 389-0206, JAPAN	TEL.81-267-32-5916	FAX.81-267-32-5928
<b>TAIWAN</b>	CINCOM MIYANO TAIWAN CO., LTD. 10FL., No.174, Fuh Sing N. Rd., Taipei, TAIWAN	TEL.886-2-2715-0598	FAX.886-2-2718-3133
<b>CHINA</b>	CITIZEN (CHINA) PRECISION MACHINERY CO., LTD. 10058, XINHUA ROAD OF ZHOUCUN, ZIBO, SHANDONG, P.R. CHINA	TEL.86-533-6150560	FAX.86-533-6161379
<b>EUROPE-Germany</b>	CITIZEN MACHINERY EUROPE GmbH Mettinger Strasse 11, D-73728 Esslingen, GERMANY	TEL.49-711-3906-100	FAX.49-711-3906-106
<b>EUROPE-UK</b>	CITIZEN MACHINERY UK LTD 1 Park Avenue, Bushey, WD23 2DA, UK	TEL.44-1923-691500	FAX.44-1923-691599
<b>EUROPE-Italia</b>	CITIZEN MACCHINE ITALIA s.r.l. Via Campo Romano 11/13 - 24050 Spirano (BG), ITALY	TEL.39-035-877738	FAX.39-035-876547
<b>AMERICA</b>	MARUBENI CITIZEN-CINCOM INC. 40 Bordline Road Allendale, NJ 07401, U.S.A.	TEL.1-201-818-0100	FAX.1-201-818-1877

URL:<http://cmj.citizen.co.jp/>

All specifications are subject to change without prior notice. This product is an export control item subject to the foreign exchange and foreign trade act. Thus, before exporting this product, or taking it overseas, contact your CITIZEN machine dealer. Please inform your CITIZEN machine dealer in advance of your intention to re-sell, export or relocate this product. For the avoidance of doubt products includes whole or part, replica or copy, technologies and software. In the event of export, proof of approval to export by government or regulatory authority must be evidenced to CITIZEN. You can operate the machines after the confirmation of CITIZEN. CITIZEN is a registered trademark of Citizen Watch Co., Japan.